

» **SAMSON** FLEX II Spreader



- growing together

SAMSON AGRO expands its well-known FLEX spreader series with an additional model, FLEX II 20E, and FLEX II 23E with extensions. This is a single axle spreader with a volume of 20 cubic metres, as well as some new and improved options. It builds on all the good features of the well-known SAMSON FLEX series plus improvements and new possibilities for precise application.

Box structure

The box has a tapered length to ensure uniform distribution of the material to the spreading equipment, which is important for an even spread pattern in the direction of travel. The box is constructed from high-strength Domex steel which offers high strength with a low net weight.

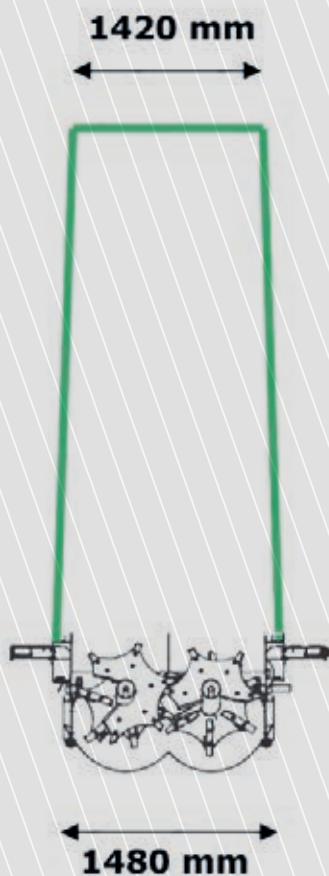

Tapered box structure.

CHOOSE THE FLEX II 20E SPREADER FROM SAMSON

The new FLEX II 20E spreader offers a wide range of unique features and solutions that increase the efficiency and quality of the work being carried out.

- Box, triangle and beaters are made of high-strength steel for a low net weight, high strength and long lifetime
- 4 strong Rübige flat chains with a high fracture strength
- Can be equipped with both vertical and horizontal beaters. This provides greater flexibility and a higher resale value
- Low loading height, despite the large volume
- Tyres with a large diameter. Can be fitted with wheels up to 2.05 m in diameter
- Choosing the new SpreadMaster 6500 and 8500 operating systems will achieve optimal utilization of the nutrients in the material. When these operating systems are combined with load cells, dosage will be extremely accurate and provide even better utilization of the nutrients in the material
- The SpreadMaster 8500 allows dosing and documentation based on an application map
- Static and dynamic weighing
- Improved access to lubrication points on the front sprockets and the opportunity for central lubrication
- Extremely high capacity



Floor chain and scrapers

All FLEX II spreaders are equipped with four strong Rübig flat chains with L-shaped scrapers. The Rübig floor chain has a fracture strength of up to 12,500 kg and is distinguished by the fact that it keeps itself clean, is able to reverse and can be disassembled easily without using tools. FLEX II 20E can also be fitted with an optional automatic chain tensioner which ensures that the tightness of the chain remains consistent and stable when driving.

Strong Rübig flat chains with L-shaped scrapers

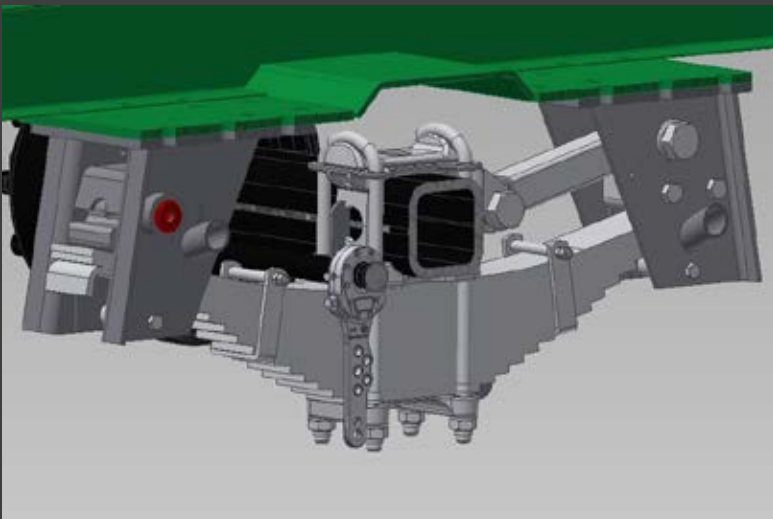

Axles and brakes

The FLEX II 20E is equipped with a strong 16-ton single-axle, either bolted or on a spring suspension, for a higher ride comfort. FLEX II 20E can be equipped with with hydraulic, air or combi brakes. So the statutory requirements for brakes can be met in all markets.

Wheel suspension with spring suspension and load cell.



Bigger wheels are an advantage

The spreader can be fitted with wheels up to 2.05 meters in diameter. This increases tread surface, reduces rolling resistance, reduces traction demand and minimizes fuel consumption. All this also helps to reduce structural damage in the soil.

Larger wheel diameters are possible.

MULTIPLE CONTROL SYSTEMS ARE POSSIBLE

FLEX II 20E is equipped with manual floor chain adjustment as standard, but can be upgraded to MuckControl, SpreadMaster or SpreadMaster 6500 8500.

MuckControl is an electronic floor chain adjustment system. SpreadMaster 6500 is an electronic control system that depends on driving conditions. SpreadMaster 6500 can also control the hydraulic functions and operate volumetric dosing. The SpreadMaster 6500 controller has a 4.3" touch screen that displays all the important functions on the main screen. SpreadMaster 6500 counts continuous load, area, time and total quantity.

The SpreadMaster 8500 controller can control the entire machine and can be operated both with buttons and via a touch screen. SpreadMaster 8500 can handle weighing on the FLEX II 20E and dose the spread volume based on the actual weight in the box – in other words, dynamic weighing, which is

weighing while spreading. A field map/application map can be uploaded to the controller, so the dosage can be controlled by these. For example, this may be in relation to the spreading of lime based on soil samples or the spreading of poultry manure based on the application map for nitrogen.

SpreadMaster 8500 can also handle a simple weighing system, in which a given volume is weighed when stationary in order to calibrate the volumetric system – static weighing.

SpreadMaster 8500 is ISOBUS-compatible. The operating system can therefore be operated via the tractors own terminal if this also is ISOBUS-compatible.



Manual floor chain adjustment - Standard



MuckControl - Option.



SpreadMaster 6500 - Option.



SpreadMaster 8500 - Option.



Triangle with space for load cells

FLEX II 20E has been given a new and reinforced triangle with space for load cells. The triangle has been extended so that it can still turn sharply even with large rear tyres on the tractor.

The extended drawbar with space for load cells.

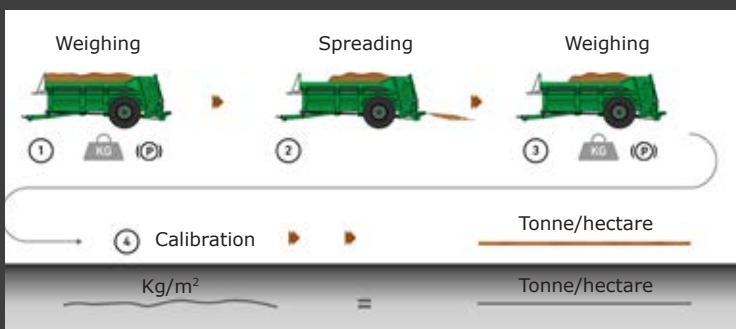

Static weighing



Dynamic weighing

Static or dynamic weighing

FLEX II 20E can be equipped with load cells on a triangle and axle, which permits both static or dynamic weighing. This gives a very precise dosage, regardless of the material. The weighed volume can be counted together, so the relevant documentation can be prepared.



Optimal lubrication with central lubrication

FLEX II 20E can be equipped at the factory with a central lubrication system from German company Beka. The system features a Beka Pico pump with a 1.5 litre reservoir. SAMSON is the only spreader manufacturer that can offer this pump with stirring inside the reservoir. The pump has a strong aluminium pump housing, while the distributors and fittings are made with a special alloy for longer lifetime. The central lubrication ensures that all lubrication points are lubricated frequently and with the right amount. This provides optimal lubrication, less maintenance, longer machine durability and a higher resale value.

Besides the optimal lubrication, a better resale value can be obtained for the spreader with central lubrication.



12 meter spreading equipment

The 12 meter spreading equipment from SAMSON is a versatile spreading system for all types of material. It is designed with two vertical beaters and hinged deflectors. The 12 meter equipment can handle volumes from 4 t/ha up to 70 t/ha. The 12 meter spreading equipment is fitted with SAMSON's own gearbox, which is known for its high strength and reliability.



24 meter spreading equipment

There is also a wide spreading system with two horizontal beaters and a spreading table with two rotating deflectors. This equipment is particularly well suited for handling lightweight/finely ground natural fertilizers and spreadable industrial waste from 3 t/ha up to 50 t/ha. The deflectors have a diameter of 1200 mm for a large working width. The large wearing parts on the spreading table are made from Hardox high-strength steel for minimal wear.



Dosing gate and indicator

FLEX II can be supplied with a hydraulic dosing gate, which is used both to regulate the dosage and to contain the material during road transport. A dosing gate indicator is available as an accessory for the dosing gate, providing a visual indicator on the front of the spreader for the height of the gate.



Hydraulic floor chain tensioner

Like all our other spreaders, FLEX II can be equipped with a hydraulic floor chain tensioner. This ensures consistent tightness of the floor chain for less wear, better conveying of the material and a higher resale value.



SPREADING LIMITER

The spreading limiter is hydraulically operated with a double acting cylinder. You have the option to manually adjust the height of the limiter. It can be mounted on the right, left or both sides at the same time.

FLEX II 20E can be supplied with optional spreading limiters. To the right, left or both sides.



NEW WHEEL GUARD DESIGN

The wheel guards on the FLEX II 20 have been given a new streamlined design so the manure falls off easily.

The new wheel guards can be added as an option

NEW OPTIONS:

- Volumetric dosage
- Static weighing
- Dynamic weighing
- VRA – variable dosage
- New SpreadMaster 6500 and 8500 control
- Larger wheel diameter
- New wheel guard design
- New spreading limiter
- Central lubrication

» TECHNICAL DATA

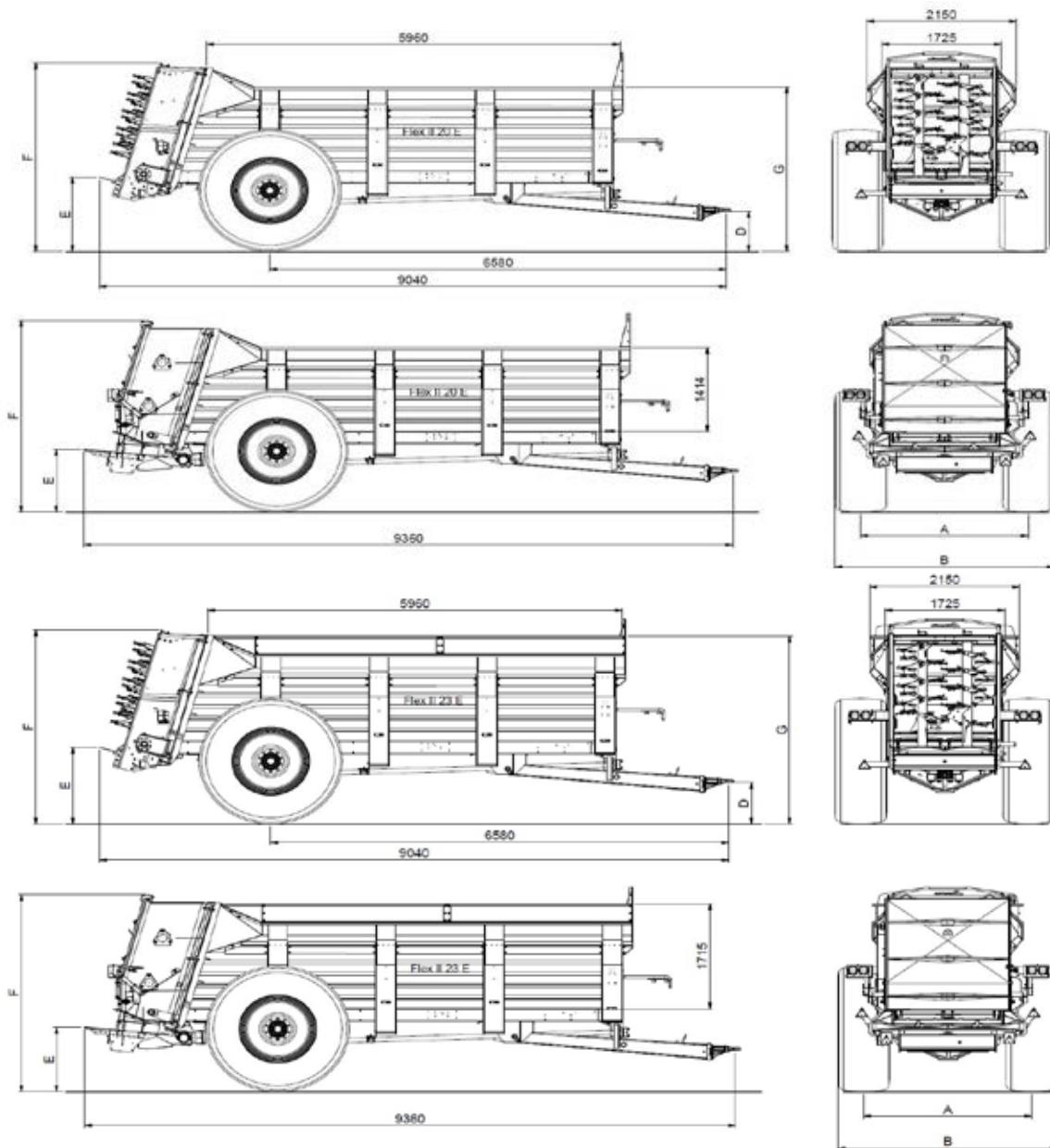

Wheelmounting	Diameter	Width	Width		Height						Weight			
			A	B	D	E 24m	E 12m	F 24m	F 12m	G	G	12m	24 m	
Alliance 680/85 R32 type 376	1960	660	2330	2990	532	912	1107	3087	3032	2627	2908			
Alliance 710/70 R38 type 360 HS	1948	716	2410	3126	527	907	1102	3082	3027	2622	2903			FLEX II 20E
Alliance 710/70 R42 type 365	2055	740	2410	3150	586	966	1161	3141	3086	2681	2962			FLEX II 23E
Alliance 800/65 R32 type 360 HS	1850	800	2470	3270	475	855	1050	3030	2975	2570	2851			

Weight is indicative and dependent on the configuration of each machine.



www.samson-agro.com