



GROWING TOGETHER

SAMSON TG



03	SAMSON TG SERIES
04	HIGH PERFORMANCE HIGH RELIABILITY
05	CONSIDERED DESIGN
07	VERSATILE USE OPERATING COMFORT
08	MORE FILLING OPTIONS
10	FILLING SYSTEMS FOR SAMSON TG
11	SAMSON EJECTOR FAST AND EASY FILLING
15	IMPLEMENT MOUNTING LIFTING FORCE OF 3.8 TONNES
16	INJECTORS
17	DRIP HOSE BOOMS
18	CONTROL SYSTEMS FOR YOUR SAMSON TG
20	HIGH UNLOADING CAPACITY
21	EXACT DOSAGE EVEN NUTRIENT CONTENT
24	USEFUL EXTRA FUNCTIONS
25	SAMSON SERVICE AND DEALER NETWORK
26	SAMSON AGRO
27	SAMSON GROUP

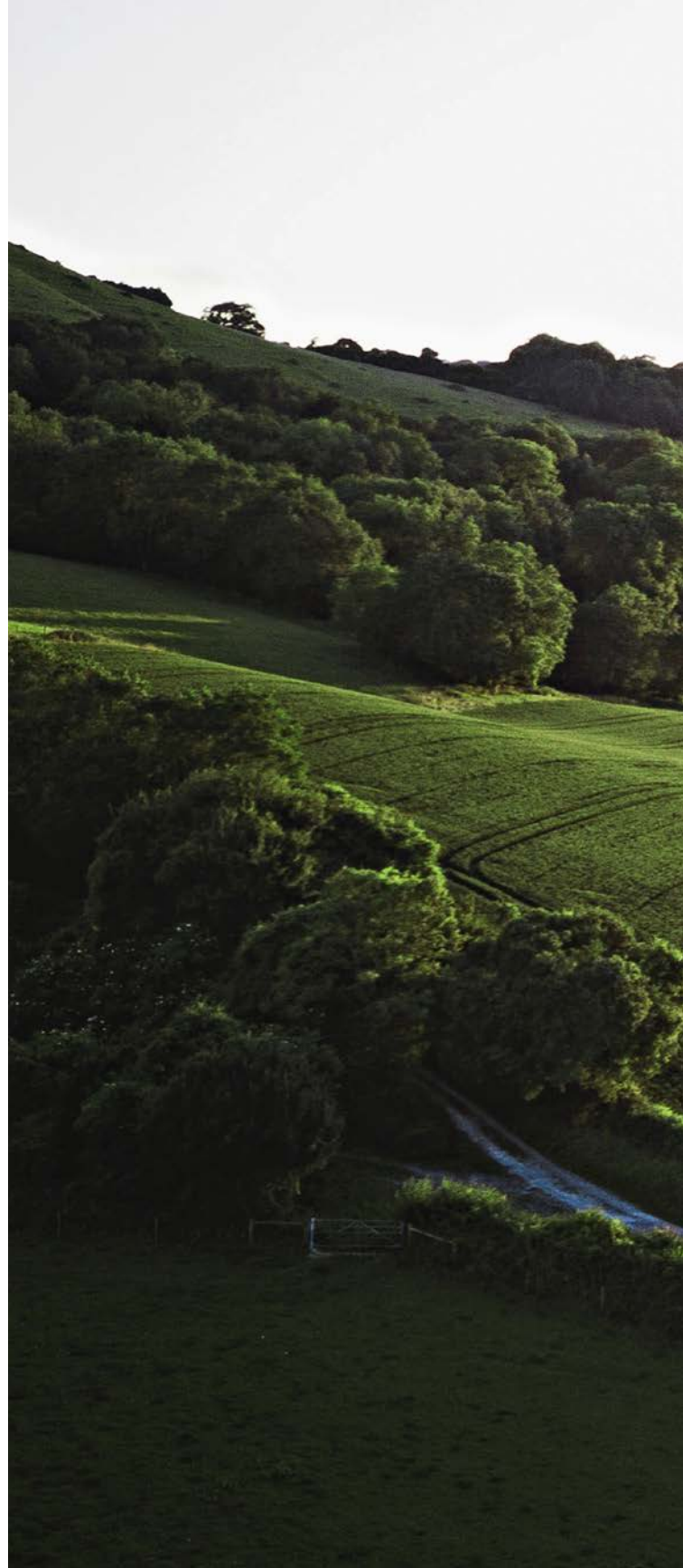

SAMSON TG

Quality, high performance and reliability are the hallmarks of the new SAMSON TG series. The models in this series are designed for versatile use and efficient slurry application. Two SAMSON TG models are available: TG 18 and TG 20.

High performance High reliability

The development of SAMSON TG has focused on efficient and precise application combined with minimal maintenance and high reliability. The tanker can be combined with several of SAMSON AGRO's leading filling systems and application implements and is designed according to SAMSON's high quality standards. The built-in implement flexibility gives the tanker with a wide range of applications and high functionality. SAMSON TG is being launched in 18.2 and 20.4 cubic metre versions.



Basic model

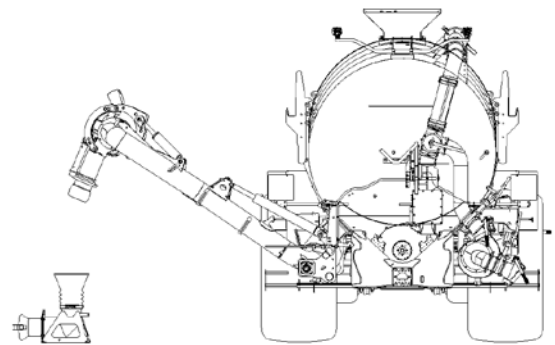
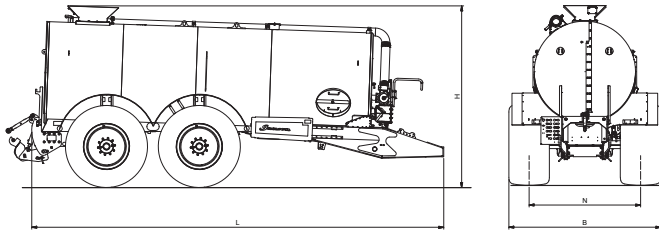

Basic model - with SAP 2

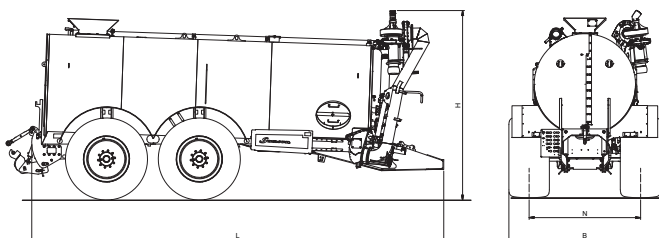



Considered design

SAMSON TG has been developed with an eye for weight distribution, strength and comfort. The series features a hydraulic chassis, large brakes and a self-levelling rotating shaft with hydraulic lock, which makes the tanker both simple and flexible. Electronic wheel steering* and the positioning of the wheel shafts provides optimal weight transfer to the tractor and contributes to the TG model's special manoeuvrability during both application and transport.

The tank is designed with sectional emptying as standard, which means that the rear part of the tank is emptied first. This results in greater weight transfer to tractor during application and minimises the risk of field damage caused by wheel slip. The inside of the tank is sand blasted, primed and epoxy treated, while the outside is sand blasted, primed and painted. The thorough surface treatment both internally and externally ensures maximum robustness even in aggressive environments and contributes to the tanker's long service life, ease of cleaning and ultimately lower maintenance costs.

* Optional



Versatile use

Operating comfort

The durable and functional design behind the SAMSON TG model prepares it for versatile use. With a wide choice of options, you can configure your tanker exactly as you need. The universal cat. 3 lift* means you can use a variety of different injectors and drip hose booms from the SAMSON AGRO implement range.

The outputs and control units are located at a user-accessible height and extra features* make your working life much easier, such as a water tank with soap dispenser to wash your hands, a tool box and visual instructions placed directly on the machine.



More filling options

The SAMSON TG can be configured with a variety of different filling systems. Combined with SAMSON AGRO's unique ejector system*, the following solutions can be selected for fast loading of the tank:

- The tanker's integrated filling coupling
- Hose with filling pump* mounted on the side of the slurry tanker
- SAP 1* (Side-mounted single link filling arm)
- SAP 2* (Side-mounted double link filling arm)
- FAP* (Separate front-mounted pump unit suspended on the tractor's front hitch)

You can also choose to use the built-in funnel on top of the tanker for external filling from a stationary or mobile pump unit.

The versatility of the TG model filling systems means it is suitable for pumping different types of slurry from different types of installation, including from low-lying or difficult to access slurry tanks or via suction connectors in biogas plants, for example.



* Optional



Filling systems for SAMSON TG



SAP 1* Single link side-mounted filling arm with integrated pump. Simple and fast filling of the slurry tanker from a low funnel.



SAP 2* Double link side-mounted filling arm with integrated pump. Universal filling arm with the option of filling from a low or high filling funnel with a coupling and from difficult to access slurry stores.

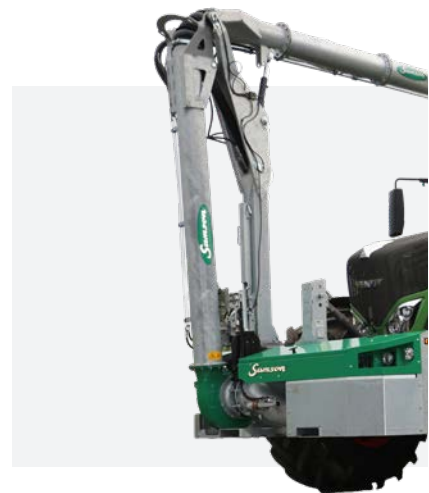

FAP* Front filling system with integrated pump. The FAP system ensures simple and easy filling from a high filling funnel such as a truck or mobile reservoir.

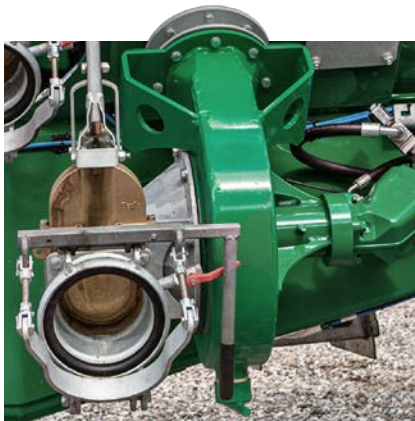

Side-mounted filling pump* Side-mounted filling pump with manual slide valve and quick hose coupling.



Filling coupling with hydraulic slide valve* Integrated filling coupling provides fast access to filling directly via the SAMSON ejector*. Fitted with quick coupler for the hoses and hydraulic slide valve* with external control.



External filling Wide filling funnel with removable valve plate, venting valve and safety valve. The funnel can be opened via a hydraulic slide valve to allow external filling from a stationary or mobile pump unit.

* Optional

SAMSON Ejector

Fast and easy filling

SAMSON TG is ready for use with the SAMSON ejector system*. A unique and patented ejector vacuum pump system that can pump even the most demanding liquids. The system has a performance of up to 6,000 litres per minute in water at a discharge head of 1 metre. The vacuum down to -0.9 bar is created only in the

ejector's pipe system and not the entire slurry tank. This keeps the slurry tanker's net weight to a minimum and ensures a fast vacuum response time, enabling filling to start quickly. The system contains no mechanical pump elements, which minimises maintenance costs.

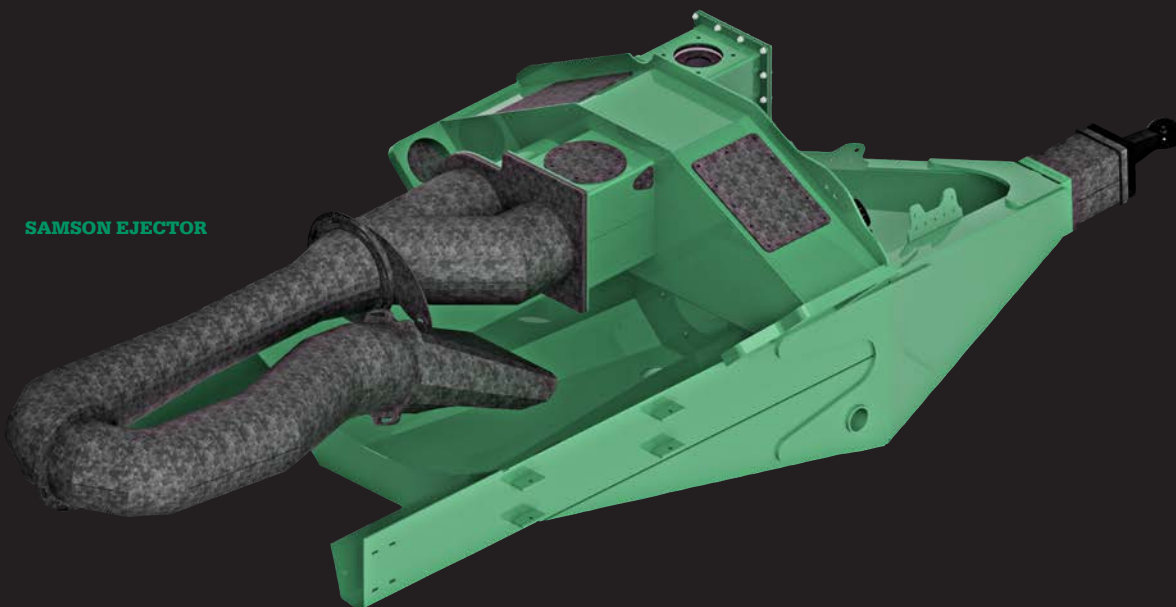

The SAMSON ejector system uses a small amount of slurry, retained in the reservoir at the front of the slurry tanker. The slurry in the reservoir helps to ensure good weight transfer to the tractor. If the ejector is not used, disconnect the reservoir so you can use the total volume of the slurry tanker during operation.

* Optional





GROWING TOGETHER

We aim to play a leading role in developing natural fertilizer machinery and technology for professional agriculture with consideration for people and the environment.



Implement mounting

Lifting force of 3.8 tonnes

SAMSON TG can be equipped with a fixed implement bracket* or a cat. 3 three-point lift*, which has the power and functionality to give you the freedom to vary the type of implement and to solve a variety of tasks. The lift has a lifting force of up to 3.8 tonnes and a pressure force of 5 tonnes. It can be set to either double or single acting operation, which ensures that it can both lift and press and hold a stable working depth. A hydraulic push and pull output* close to the lift makes it easy to mount and remove implements.



* Optional

Injectors

TE SERIES

TE single disc injectors are designed to achieve optimal utilisation of the slurry's fertilization value in growing crops. TE has a working width of 8 metres.

TE 8



TD SERIES

TD double disc injectors are designed to achieve an optimal utilisation in grass or other crops in heavy or dry soil types.

TD 8



CM SERIES

CM black soil injectors ensure optimal utilisation of the slurry's fertilization value when injecting in stubble fields and black soil. CM black soil injectors are supplied in working widths of 6 and 7.5 metres.

CM 6
CM 7.5



Drip hose booms

SB SERIES WITHOUT ADS

SB drip hose booms are supplied in widths of 12 to 24 metres. SB booms are fitted with a vertical distributor.

SB 12
SB 16-18-20-24 FOLDED AT 16M
SB 16-18-20-24 FOLDED AT 16M WITH SECTION DISTRIBUTOR



SB AND SBX SERIES WITH ADS

SB and SBX drip hose booms can also be supplied with ADS (Anti Drip System) and are fitted with a vertical distributor. SB booms with ADS are supplied in widths of 12, 12-16 or 12-18 metres. SBX in widths of 24 metres.

SB 12 ADS
SB 12-15-16 ADS
SB 12-15-18 ADS
SBX 16-18-20-24 FOLDED AT 16M OR 18M
SBX 16-18-20-24 FOLDED AT 16M OR 18M WITH SECTION DISTRIBUTOR



SBX2 SERIES

SBX2 drip hose booms are supplied with 2 distributors and always with ADS. They are supplied as combi booms with variable widths depending on how far the booms are folded out. The TG series uses SBX2 models in widths up to 24 metres.

SBX2 16-18 FOLDED AT 18M
SBX2 16-18-20-24 FOLDED AT 16M OR 18M



Control systems for your SAMSON TG

SAMSON TG can be controlled very simply via the **tractor hydraulics**. Hydraulic functions are driven by the tractor without electronic control systems.

With the **SlurryMaster 3000***, all the functions can be controlled by the electric hydraulic system, without the driver having to leave their seat. The system is built in the traditional manner with switches, wires and relays. The system is simple and easy to understand and therefore easy to operate.

SlurryMaster 5000* is a control unit with a 7" touch screen and multi-functional navigation wheel. The new control unit allows the user to connect a flow meter and thus to use SAMSON's Auto Dosing system. The system is also designed for ease of use and machine functionality. SlurryMaster 5000 features SAMSON's familiar automation technology, providing extremely smart interaction between the control unit and slurry tanker.

SLURRY MASTER 3000



SLURRY MASTER 5000

* Optional



At SAMSON AGRO, great emphasis is placed on product development. The company has a large team of engineers who continuously develop and update the products in order to maintain our position as the leading specialist in natural fertilizer machinery and application technology.

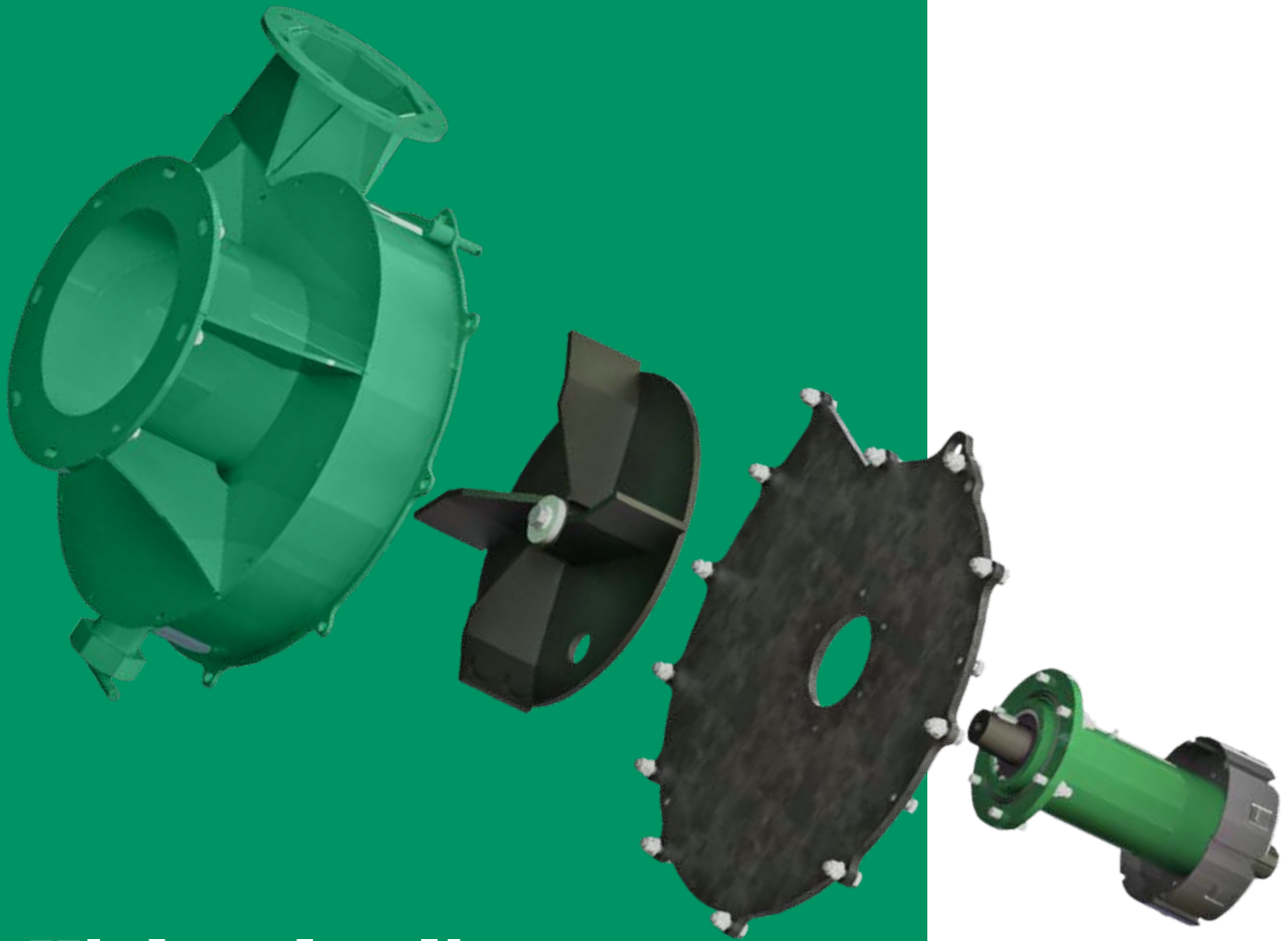

High unloading capacity

SAMSON TG is supplied as standard with a specially developed SAMSON unloading pump with a performance of up to 10,000 litres per minute. The model can also be delivered with a pump* with a capacity of up to 15,500 litres per minute. Both solutions are designed to fully exploit SAMSON application technology, even at low engine speeds. SAMSON pumps are not vulnerable to foreign objects, including stone, steel and plastic, and the simple design and robustness of the pump help to reduce maintenance costs.

* Optional



Exact dosage Even nutrient content

In order to ensure a homogeneous slurry, the SAMSON TG is equipped with a mixing function. The unloading pump pumps slurry into the three-way valve, which measures the correct dosage or application and pumps the slurry into the tanker to mix the slurry. This ensures that the slurry to be applied in the field has a constant content of nutrients and organic materials, resulting in the uniform fertilization of crops.

SAMSON TG can be controlled in combination with SlurryMaster 5000 with a flow meter*. The flow meter is completely maintenance free and has no mechanical moving parts. In the steering system, enter the required number of cubic metres of slurry to be applied per hectare. The amount of applied slurry is then regulated based on the flow meter readings. This provides a very exact slurry dosage, whether driving up or down hill.

* Optional

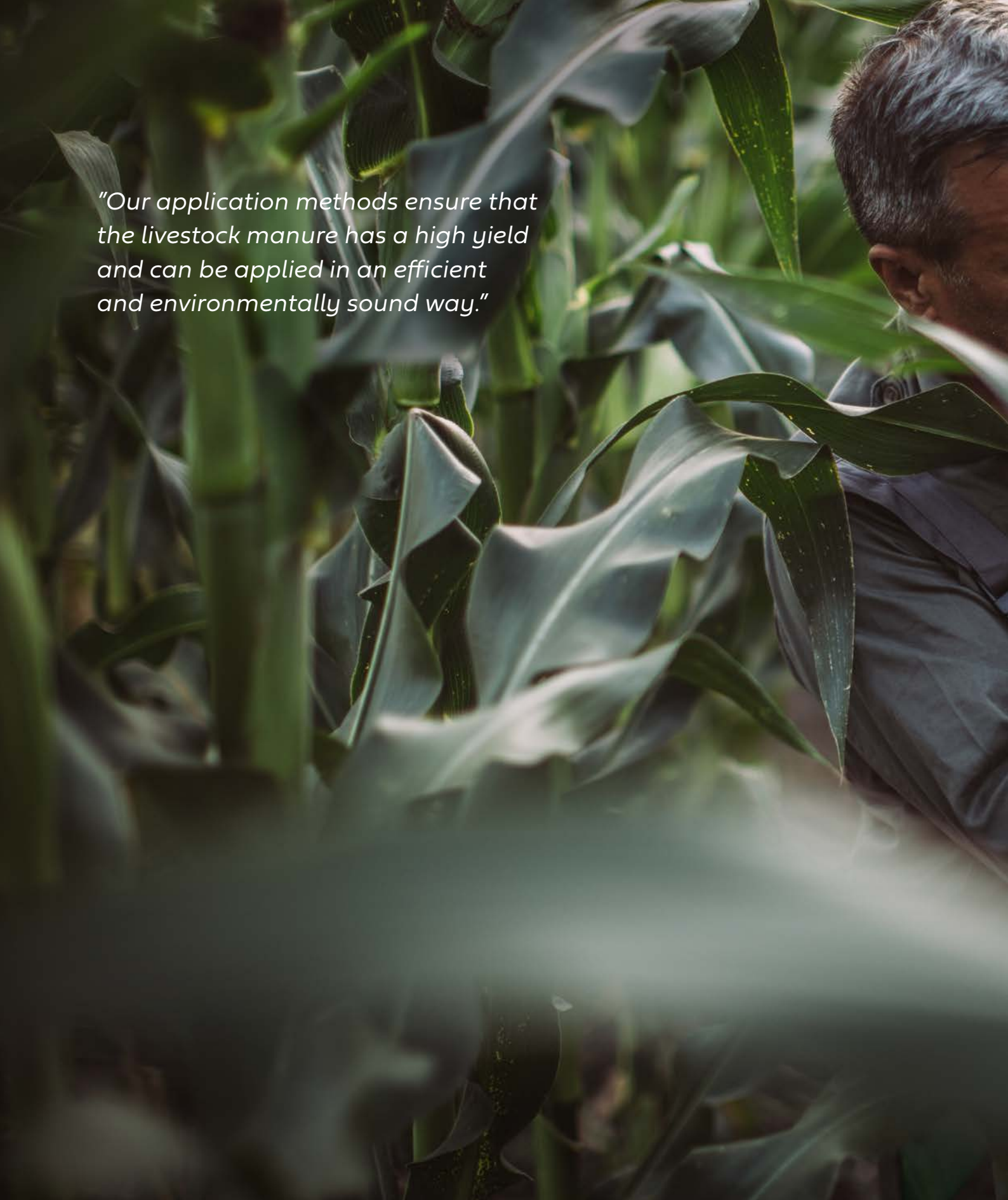
A close-up photograph of a man with short, graying hair, wearing a dark-colored shirt, looking down at a field of corn plants. The corn leaves are large and green, with some showing signs of being eaten or damaged. The lighting is soft and natural, suggesting an outdoor setting during the day. The man's face is partially visible on the right side of the frame, and he appears to be focused on the plants.

"Our application methods ensure that the livestock manure has a high yield and can be applied in an efficient and environmentally sound way."



Useful extra functions

GOOD LIGHTING

The TG is equipped with LED lights, which are very reliable and require minimal maintenance. The working area is also illuminated via powerful high LED lamps*, which increase safety and capacity even after nightfall.



AUTOMATIC TYRE PRESSURE REGULATION

The TG can be supplied with automatic tyre pressure regulation*, so the driver can set a desired tyre pressure when driving from one surface type to another. It can also be set according to the soil and crop type. This way you can reduce pressure and driving damage as much as possible.



CENTRALLY LOCATED LUBRICATION POINTS

The TG has centrally located lubrication points*, which simplifies daily servicing on a busy working day. In addition, TG can be equipped with automatic central lubrication*, where the equipment is lubricated with the right amount at the right intervals.



* Optional

SAMSON service and dealer network

When you choose a SAMSON product, you will benefit from our large and well-established network of dealers, who are available to provide excellent service and special knowledge of our machines and equipment.

SAMSON dealers are in close and continuous contact with SAMSON AGRO, who place great importance on individual SAMSON specialists achieving expert knowledge through the SAMSON ACADEMY training program. A smooth and efficient service concept also ensures that every customer is served professionally both before during and after a purchase.

SAMSON AGRO maintains a large stock of spare parts to ensure the fast and efficient maintenance and upgrade of all SAMSON machines and products.

Fertilizer based on natural nutrients

SAMSON AGRO produces slurry tankers and manure spreaders with the aim of achieving maximum application efficiency and optimal use of the nutrients in natural fertilizer. We supply a wide range of natural fertilizer machines, implements and application technology, where all elements in the fertilizer process are considered. Our goal is to meet the agricultural industry's demand for innovative, environmentally sound, high quality solutions for the application of natural fertilizers.



SAMSON GROUP

SAMSON GROUP comprises the companies SAMSON AGRO A/S, Samson Agrolize A/S, SAMSON AGRO SASU and SAMSON AGRO SP Z.o.o. The group owns the SAMSON and PICHON brands and is a leading European supplier of natural fertilizer machines and associated application technology. SAMSON GROUP has state-of-the-art production units in Denmark, France and Poland and sells its products through a well-established network of dealers.

SAMSON - GROWING TOGETHER

Technical data

Dimensions in m / tanker size		TG 18	TG 20
Length	L	8.60	8.60
Tanker diameter	∅	1.95	2.05
Height*	H	3.70	
Alliance 23.1-26 - Type 330 HD 16PR	B	2.84	
Nokian 800/50-R34 - Radial type ELS SB	B	2.98	
Hub gauge	N	2.15	
Net weight**	kg	8400	8680
Volume	m ³	18.2	20.4

* Max. height with filling funnel

** Net weight for basic tanker with only standard equipment

Dealer

--	--